



Stainless steel bottom grill

- + Capacity: 42 bottles*
- + Free standing and built-under counter installation
- + Design: black body & stainless steel door frame
- + Cooling system: compressor
- + Type of cold: air moving system
- + Adjustable temperature ranges of use: 5°-20°C
- + Electronic regulation
- + Thermometer with white electronic display
- + White LED lights with switch button
- + Humidity control: water tray
- + 2 glass doors, anti-UV treated, 2-layers tempered glass (brown colored)

*New elegant design and optimization of energy consumption: **A class.***
*Thanks to the black shelf provided with your wine cellar, you can also arrange your opened **bottles vertically** for example!*



Eco-responsibility

Our products are manufactured in compliance with European environmental rules. Especially, refrigerant fluid (R600a) doesn't reject neither CFC nor HFC and respect environment.

Energy consumption is calculated based on the result obtained for 24h in standard test conditions. The actual energy consumption depends on the conditions of use and location of the device.

This equipment is designed to be used in an ambient temperature between 16°-32°C.

This appliance is intended to be used exclusively for the storage of wine.

Alcohol abuse is dangerous for health, please consume in moderation.

*Capacity given as an indication with 75cl Bordeaux traditional type bottles and measured with 4 shelves. Adding shelves reduce considerably the total capacity.

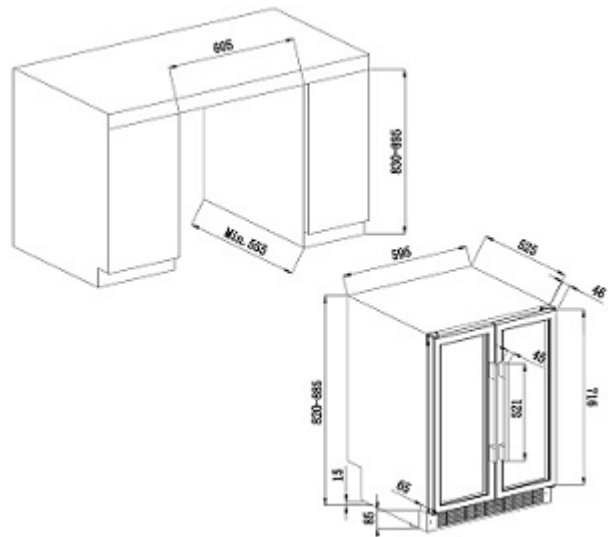

Reference: AVU41SXDPA
2-compartments service wine cabinet
Built-under counter range



> EQUIPMENTS INCLUDED

- 4 semi-sliding wire shelves, wooden front
- 4 semi-sliding wire half-shelves, wooden front
- 4 adjustable feet (height 6.5 cm)
- Passage de plomberie
- Anti-vibration system
- Removable aeration system

> TECHNICAL CHARACTERISTICS

- Energy class: A
- Annual electrical consumption: 144 kWh
- Climatic class: N (16°-32°C)
- Noise level: 43 dB
- Voltage: 220-240 V
- Power input: 107 W
- Category: 2 - Wine cellar
- Type of gas : R600a

> LOGISTIC DATAS

Gross dimensions (WxDxH cm)	: 65,5 x 66,5 x 87
Net dimensions (WxDxH cm)	: 59,5 x 57,1 x 82
Gross weight (kg)	: 52.00
Net weight (kg)	: 48.00
Full truck (pcs)	: 120
Container (pcs)	20' : 48
	40' : 108
	40' HC : 162

Gencod 3595320105131

> COMPATIBLE ACCESSORIES

Only available in spare parts